

Alfa Poland

AUTOMATION SYSTEMS

Alfa Poland Sp. z o.o.
ul. Grażyńskiego 141
43-300 Bielsko-Biała
tel.: +48 33 488 55 00
alfapoland@alfapoland.pl
www.alfapoland.pl



BUDOWA MASZYN, AUTOMATYKA I ROBOTYKA

Kompleksowa budowa linii montażowych, budowa maszyn oraz celi zrobotyzowanych, budowa pojedynczych stanowisk montażowych, budowa stanowisk zgrzewalniczo-spawalniczych, stanowiska kontroli wizyjnej produktów, automatyzacja procesów technologicznych;

Turnkey construction of assembly lines, construction of machines and robotic cells, construction of single assembly stations, construction of spot-welding and welding stations, vision inspection stations for products, automation of production processes;

Kompleksowa budowa linii montażowych, budowa maszyn oraz celi zrobotyzowanych, budowa pojedynczych stanowisk montażowych, budowa stanowisk zgrzewalniczo-spawalniczych, stanowiska kontroli wizyjnej produktów, automatyzacja procesów technologicznych;



RELOKACJA I TRANSPORT MASZYN

Relokacja maszyn, urządzeń i linii produkcyjnych „pod klucz”, demontaż i montaż maszyn i instalacji przemysłowych, transport, pozycjonowanie, podłączenia mediów, uruchamianie maszyn;

Machinery, devices and production lines „turnkey” relocation. disassembly and reassembly of machines, production lines and industrial installations, transport, positioning, media connection, machinery start-up;

Manutenzione di macchinari, impianti e linee di produzione secondo la formula „chiavi in mano”, smontaggio e rimontaggio dei macchinari e impianti, trasporto, posizionamento, allacciamenti;



UTRZYMANIE RUCHU

Prowadzenie predykcyjnego utrzymania ruchu, planowanie i przeprowadzanie przeglądów maszyn, czyszczeń technicznych, remontów i modernizacji, aktywna współpraca z klientem dla osiągnięcia maksymalnego czasu dyspozycyjności maszyn produkcyjnych przy wykorzystaniu metodologii TPM;

Preventive maintenance, planning and conducting machine inspections, technical cleaning, overhauls and modernisation, active cooperation with the customer to achieve maximum uptime of production machines using TPM methodology, purchasing and logistics management of spare parts for machines;

Kompleksowa budowa linii montażowych, budowa maszyn oraz celi zrobotyzowanych, budowa pojedynczych stanowisk montażowych, budowa stanowisk zgrzewalniczo-spawalniczych, stanowiska kontroli wizyjnej produktów, automatyzacja procesów technologicznych;



SPRZEDAŻ PRODUKTÓW PRZEMYSŁOWYCH

Alfa Poland jest autoryzowanym dystrybutorem materiałów oraz urządzeń przemysłowych następujących firm: CLECO - najwyższej klasy elektryczne i pneumatyczne narzędzia dokręcające, TEAFLEX - system osłony kabli elektrycznych, JAEGER HANDLING - systemy ramion reakcyjnych;

Alfa Poland is an authorized distributor of materials and industrial equipment of the following companies: CLECO - top class electrical and pneumatic tightening tools, TEAFLEX - system for guiding and protecting electric cables, JAEGER HANDLING - advanced torque arm systems;

Alfa Poland é il rivenditore autorizzato di materiali e impianti industriali dei seguenti costruttori: CLECO - Costruttore a livello mondiale del avvitatori elettrici e pneumatici, TEAFLEX - sistemi di protezione e guaine per impianti elettrici per settore ferroviario, automotive, JAEGER HANDLING - sistemi di bracci di reazione avanzati dediti alla riduzione del carico dell'attrezzo;

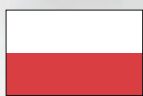

RELOKACJA I TRANSPORT MASZYN
ZESTAWIENIE SPRZĘTU



MACHINERY RELOCATION AND TRANSPORT
EQUIPMENT SUMMARY



TRASFERIMENTO E TRASPORTO DI MACCHINARI
SOMMARIO DELLE ATTREZZATURE

Alfa Poland

AUTOMATION SYSTEMS

Alfa Poland Sp. z o.o.
ul. Grażyńskiego 141
43-300 Bielsko-Biała
tel.: +48 33 488 55 00
alfapoland@alfapoland.pl
www.alfapoland.pl



WPROWADZENIE

Firma Alfa Poland dysponuje specjalnym wydziałem, który zajmuje się przeniesieniami, transportem oraz instalacjami maszyn i linii produkcyjnych.

Wyspecjalizowany personel potrafi odpowiedzieć na najtrudniejsze wymagania klientów, świadcząc usługę relokacji według zasady „pod klucz”.

Nasi technicy wyposażeni w odpowiedni sprzęt i oprzyrządowanie realizują proces relokacji z zachowaniem najwyższych norm bezpieczeństwa oraz standardów jakościowych, które obowiązują w zakresie powierzonych przez klienta prac.

W przypadku konieczności wykonania modyfikacji, prac konserwacyjnych, remontu lub modernizacji relokowanych urządzeń, firma Alfa Poland w oparciu o wieloletnie doświadczenie ma możliwość wykonania niezbędnych prac, montując urządzenia już w nowej, uzgodnionej konfiguracji.



INTRODUCTION

Alfa Poland operates a dedicated department specialising in the relocation, transportation and installation of machines and production lines. Its specialised staff is able to respond to the most challenging customer requirements by providing turnkey relocation services.

Our technicians, who have the necessary equipment and tools at their disposal, are able to deliver any relocation project while ensuring the highest safety and quality standards regardless of the task.

Thanks to our many years of experience in machine construction, automation and robotics, we are able to perform modifications, maintenance work, overhauls and modernisation of the equipment being relocated and ensure it is installed in a new and agreed upon configuration.



INTRODUZIONE

La società Alfa Poland dispone di un ente specializzato esclusivamente nei trasferimenti dei macchinari e nell'installazione delle linee di produzione del Cliente. Il team dell'ente, altamente qualificato ed esperienziato in campo di meccanica, elettrica, idraulica

e pneumatica, è in grado di soddisfare le più svariate esigenze dei clienti, erogando il servizio di trasferimento con la formula „chiavi in mano”.

I nostri tecnici, disponendo di attrezzature professionali, gestiscono l'intero processo di trasferimento (smontaggio meccanico, elettrico, idraulico e pneumatico, imballaggio, caricamento, fissaggio, trasporto, scaricamento, spostamento all'interno dello stabilimento, posizionamento, livellamento, rimontaggio e test di funzionamento).

Alfa Poland

AUTOMATION SYSTEMS

Alfa Poland Sp. z o.o.
ul. Grażyńskiego 141
43-300 Bielsko-Biała
tel.: +48 33 488 55 00
alfapoland@alfapoland.pl
www.alfapoland.pl



DŹWIGI



CRANES





GRU



Alfa α Poland

AUTOMATION SYSTEMS

Alfa Poland Sp. z o.o.
ul. Grażyńskiego 141
43-300 Bielsko-Biała
tel.: +48 33 488 55 00
alfapoland@alfapoland.pl
www.alfapoland.pl



-  DŹWIG ELEKTRYCZNY 10T
-  ELECTRIC CRANE 10T
-  GRU SEMOVENTE ELETTRICA 10T







Alfa Poland

AUTOMATION SYSTEMS

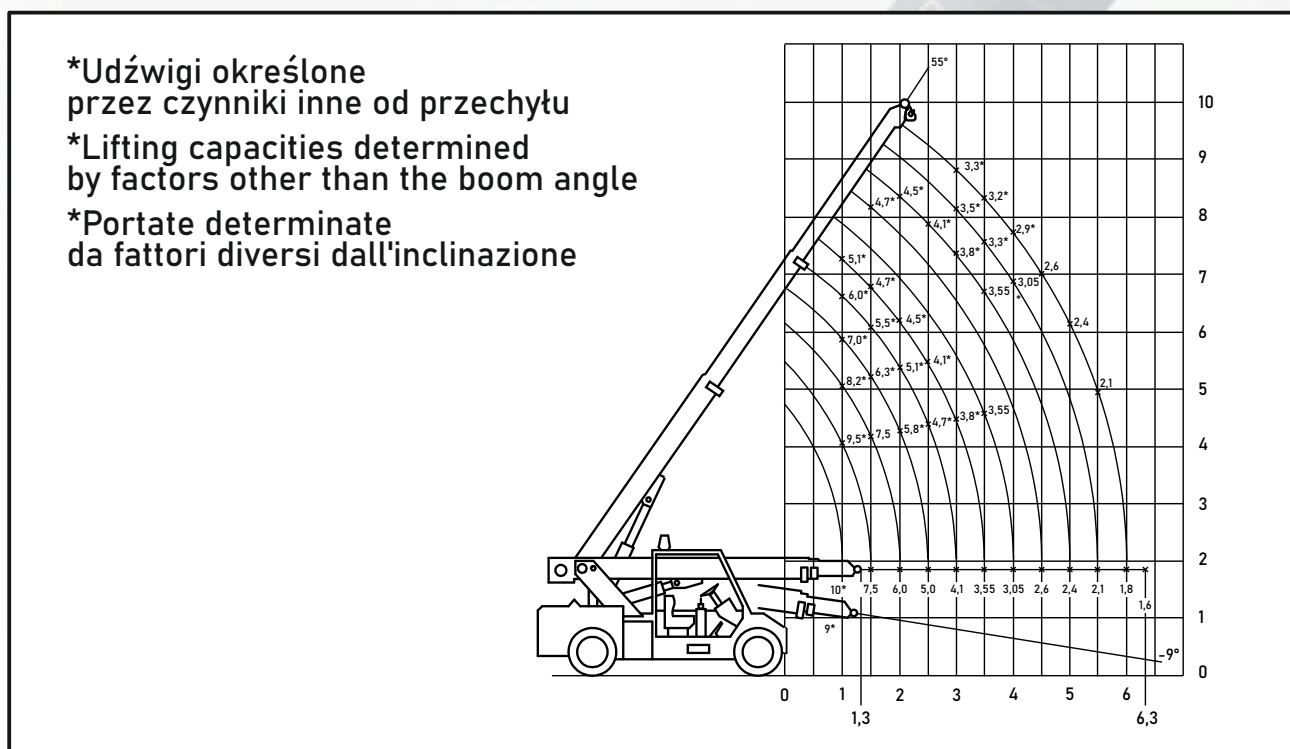
Alfa Poland Sp. z o.o.
ul. Grażyńskiego 141
43-300 Bielsko-Biała
tel.: +48 33 488 55 00
alfapoland@alfapoland.pl
www.alfapoland.pl

-  DŹWIG ELEKTRYCZNY 10T - charakterystyka udźwigu
-  ELECTRIC CRANE 10T - lifting capacity specifications
-  GRU SEMOVENTE ELETTRICA 10T - caratteristiche di portata



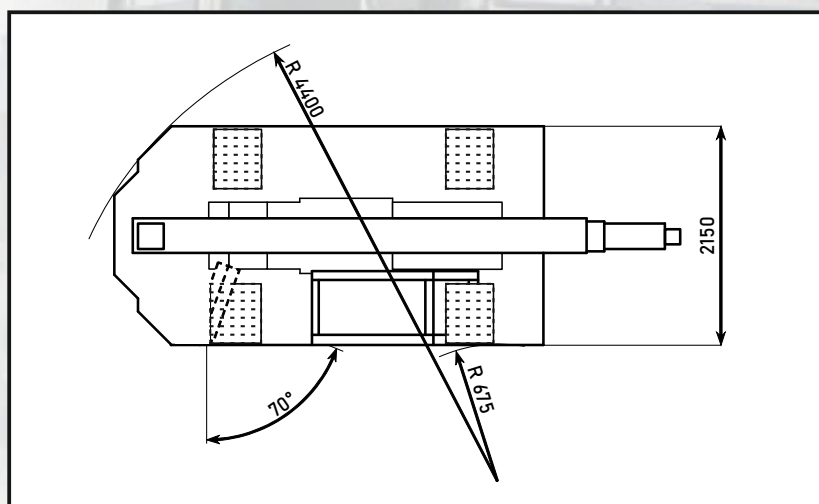

-  DŹWIG ELEKTRYCZNY 10T - wymiary
-  ELECTRIC CRANE 10T - dimensions
-  GRU SEMOVENTE ELETTRICA 10T - dimensioni



Alfa Poland

AUTOMATION SYSTEMS

Alfa Poland Sp. z o.o.
ul. Grażyńskiego 141
43-300 Bielsko-Biała
tel.: +48 33 488 55 00
alfapoland@alfapoland.pl
www.alfapoland.pl



-  DŹWIG DIESEL 15T
-  DIESEL CRANE 15T
-  GRU SEMOVENTE DIESEL 15T







Alfa Poland

AUTOMATION SYSTEMS

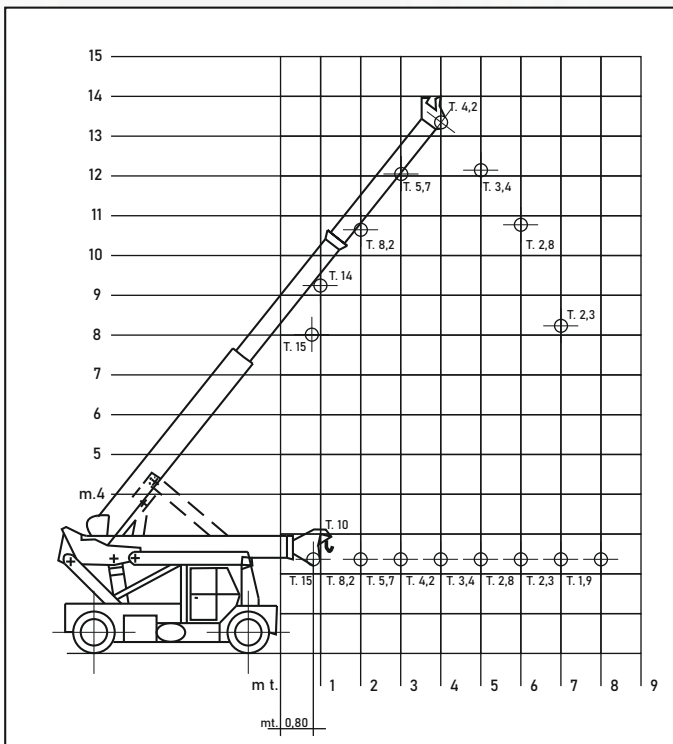
Alfa Poland Sp. z o.o.
 ul. Grażyńskiego 141
 43-300 Bielsko-Biała
 tel.: +48 33 488 55 00
 alfapoland@alfapoland.pl
 www.alfapoland.pl

-  DŹWIG DIESEL 15T - charakterystyka udźwigu
-  DIESEL CRANE 15T - lifting capacity specifications
-  GRU SEMOVENTE DIESEL 15T - caratteristiche di portata



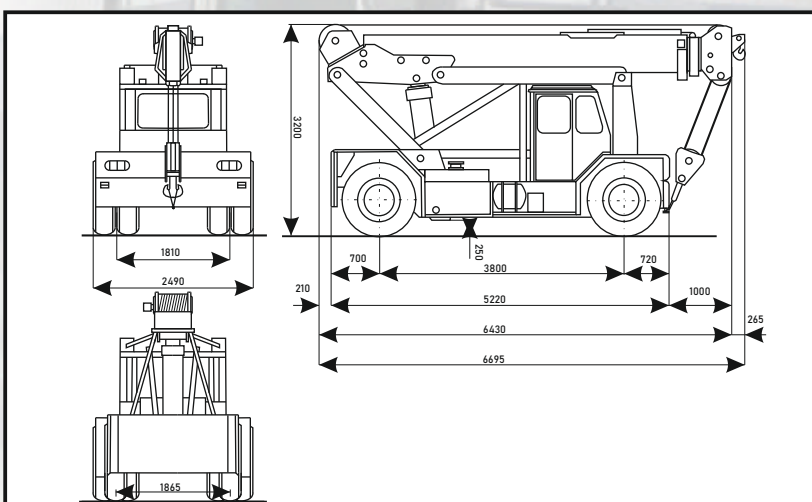

-  DŹWIG DIESEL 15T - wymiary
-  DIESEL CRANE 15T - dimensions
-  GRU SEMOVENTE DIESEL 15T - dimensioni



Alfa & Poland

AUTOMATION SYSTEMS

Alfa Poland Sp. z o.o.
ul. Grażyńskiego 141
43-300 Bielsko-Biała
tel.: +48 33 488 55 00
alfapoland@alfapoland.pl
www.alfapoland.pl



-  DŹWIG DIESEL 22T
-  DIESEL CRANE 22T
-  GRU SEMOVENTE DIESEL 22T







Alfa Poland

AUTOMATION SYSTEMS

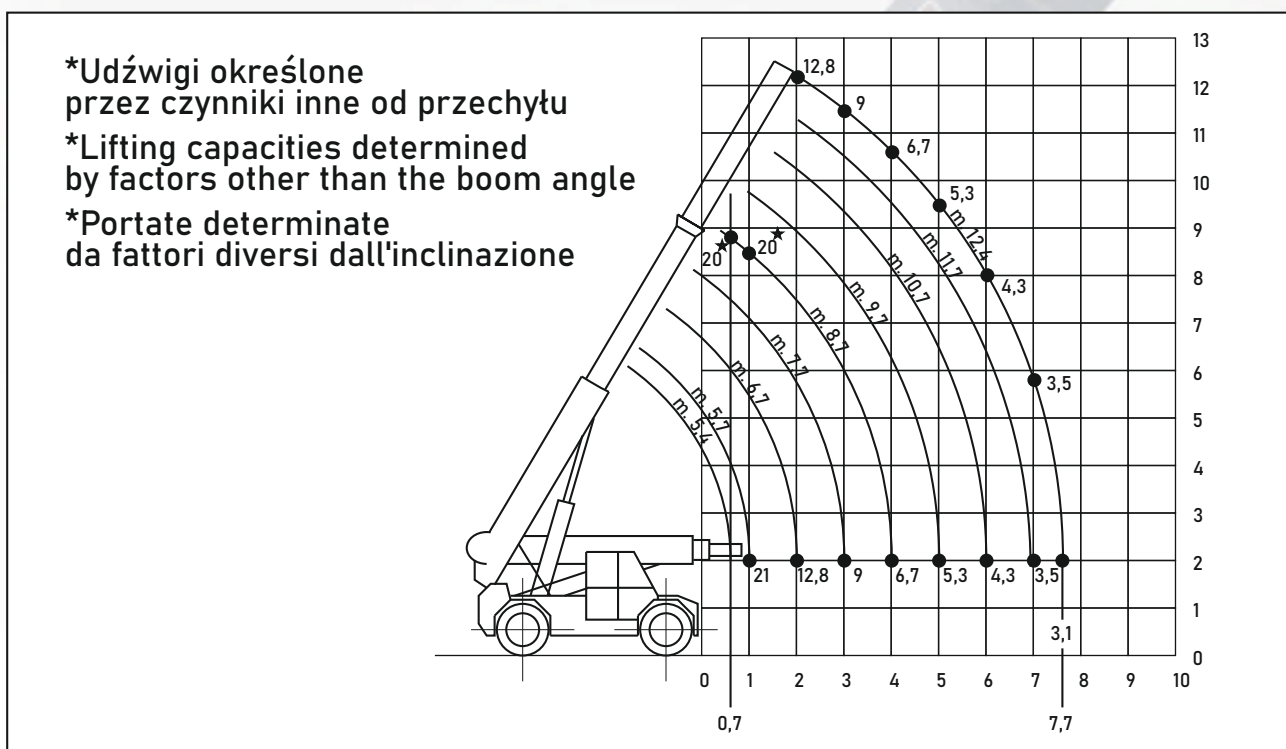
Alfa Poland Sp. z o.o.
 ul. Grażyńskiego 141
 43-300 Bielsko-Biała
 tel.: +48 33 488 55 00
 alfapoland@alfapoland.pl
 www.alfapoland.pl

-  DŹWIG DIESEL 22T - charakterystyka udźwigu
-  DIESEL CRANE 22T - lifting capacity specifications
-  GRU SEMOVENTE DIESEL 22T - caratteristiche di portata



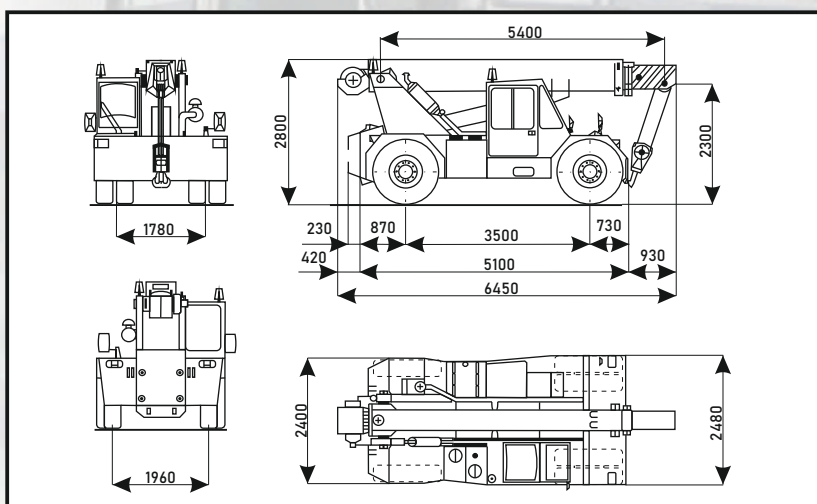

-  DŹWIG DIESEL 22T - wymiary
-  DIESEL CRANE 22T - dimensions
-  GRU SEMOVENTE DIESEL 22T - dimensioni



Alfa Poland

AUTOMATION SYSTEMS

Alfa Poland Sp. z o.o.
ul. Grażyńskiego 141
43-300 Bielsko-Biała
tel.: +48 33 488 55 00
alfapoland@alfapoland.pl
www.alfapoland.pl



-  DŹWIG ELEKTRYCZNY 22T
-  ELECTRIC CRANE 22T
-  GRU SEMOVENTE ELETTRICA 22T







Alfa Poland

AUTOMATION SYSTEMS

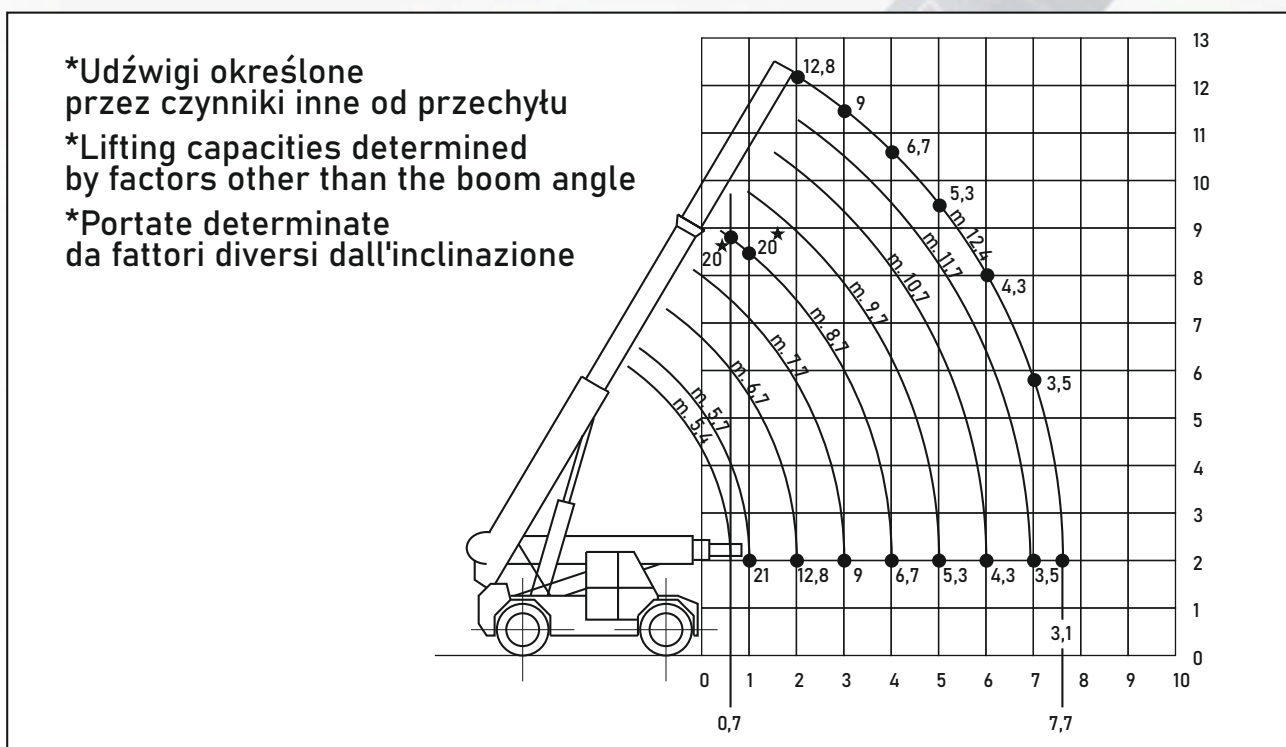
Alfa Poland Sp. z o.o.
ul. Grażyńskiego 141
43-300 Bielsko-Biała
tel.: +48 33 488 55 00
alfapoland@alfapoland.pl
www.alfapoland.pl

-  DŹWIG ELEKTRYCZNY 22T - charakterystyka udźwigu
-  ELECTRIC CRANE 22T - lifting capacity specifications
-  GRU SEMOVENTE ELETTRICA 22T - caratteristiche di portata



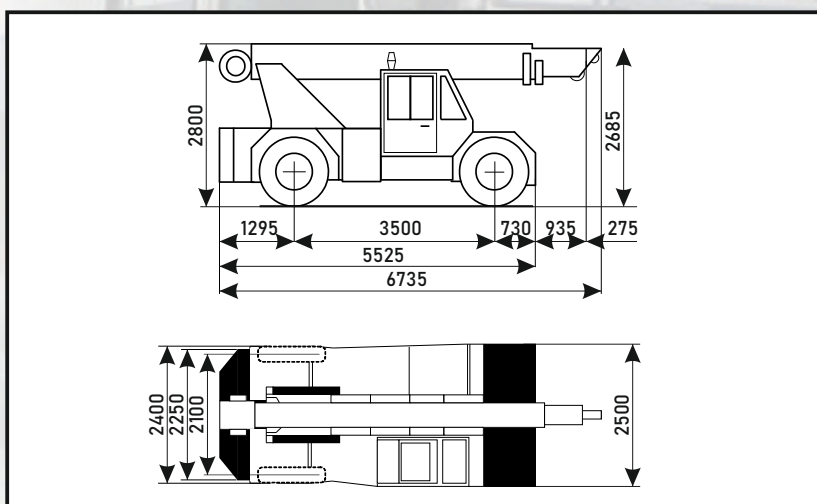

-  DŹWIG ELEKTRYCZNY 22T - wymiary
-  ELECTRIC CRANE 22T - dimensions
-  GRU SEMOVENTE ELETTRICA 22T - dimensioni



Alfa & Poland

AUTOMATION SYSTEMS

Alfa Poland Sp. z o.o.
ul. Grażyńskiego 141
43-300 Bielsko-Biała
tel.: +48 33 488 55 00
alfapoland@alfapoland.pl
www.alfapoland.pl



-  DŹWIG ELEKTRYCZNY 25T
-  ELECTRIC CRANE 25T
-  GRU SEMOVENTE ELETTRICA 25T







Alfa Poland

AUTOMATION SYSTEMS

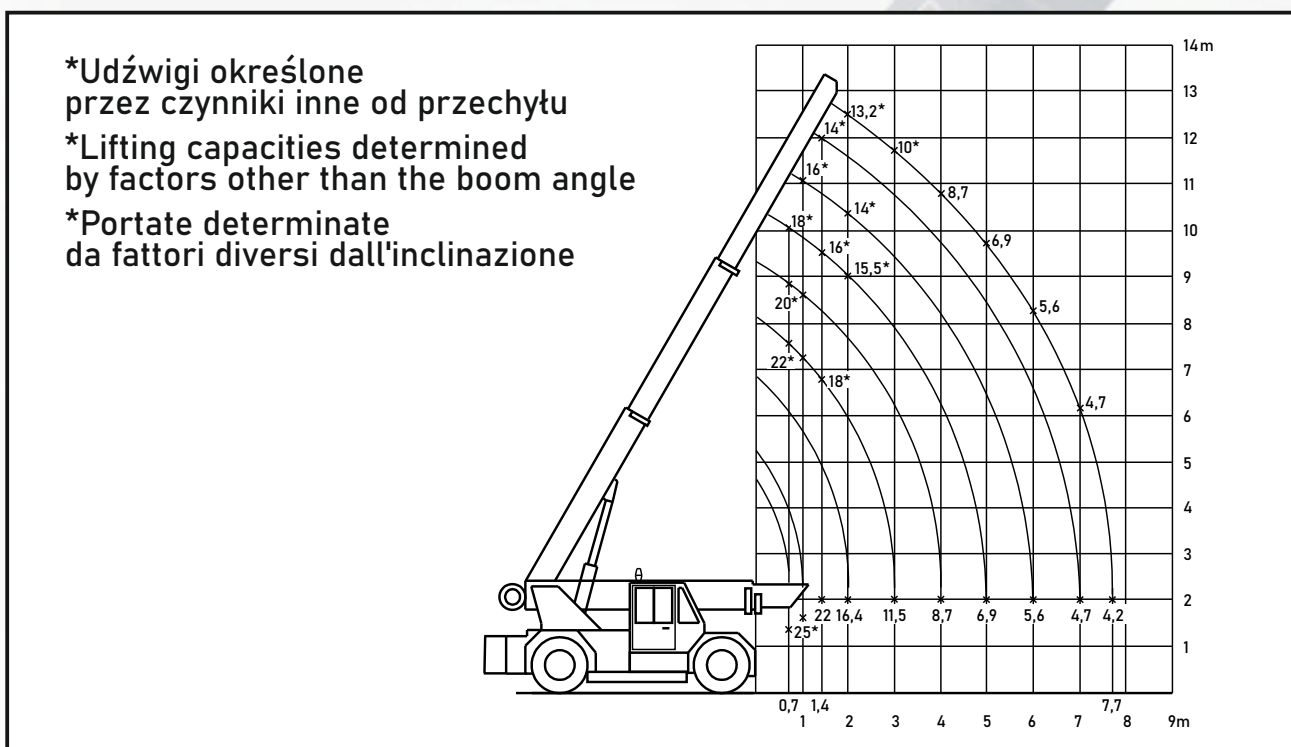
Alfa Poland Sp. z o.o.
 ul. Grażyńskiego 141
 43-300 Bielsko-Biała
 tel.: +48 33 488 55 00
 alfapoland@alfapoland.pl
 www.alfapoland.pl

-  DŹWIG ELEKTRYCZNY 25T - charakterystyka udźwigu
-  ELECTRIC CRANE 25T - lifting capacity specifications
-  GRU SEMOVENTE ELETTRICA 25T - caratteristiche di portata



-  DŹWIG ELEKTRYCZNY 25T - wymiary
-  ELECTRIC CRANE 25T - dimensions
-  GRU SEMOVENTE ELETTRICA 25T - dimensioni

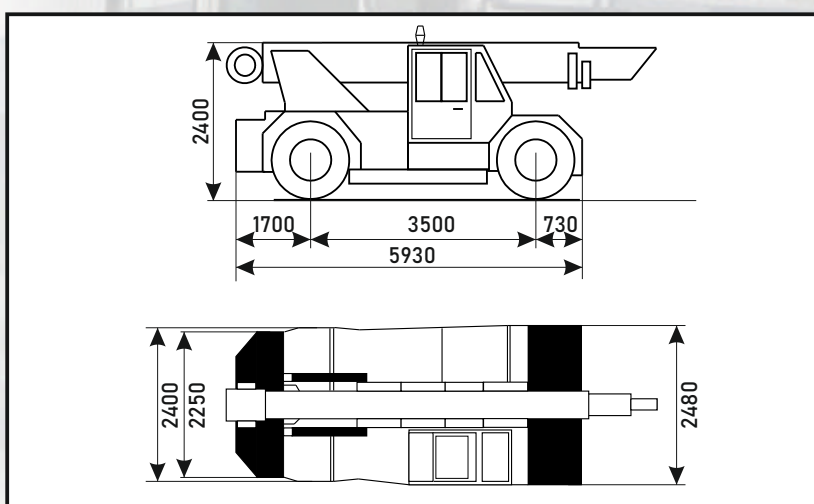

Alfa Poland

AUTOMATION SYSTEMS

Alfa Poland Sp. z o.o.
ul. Grażyńskiego 141
43-300 Bielsko-Biała
tel.: +48 33 488 55 00
alfapoland@alfapoland.pl
www.alfapoland.pl

 ŻURAW ELEKTROHYDRAULICZNY 2T

 ELECTRO-HYDRAULIC CRANE 2T

 GRU ELETTRIDRAULICA 2T

 **GRUNIVERPAL
TRANCHERO**





Alfa Poland



AUTOMATION SYSTEMS

Alfa Poland Sp. z o.o.
 ul. Grażyńskiego 141
 43-300 Bielsko-Biała
 tel.: +48 33 488 55 00
 alfapoland@alfapoland.pl
 www.alfapoland.pl

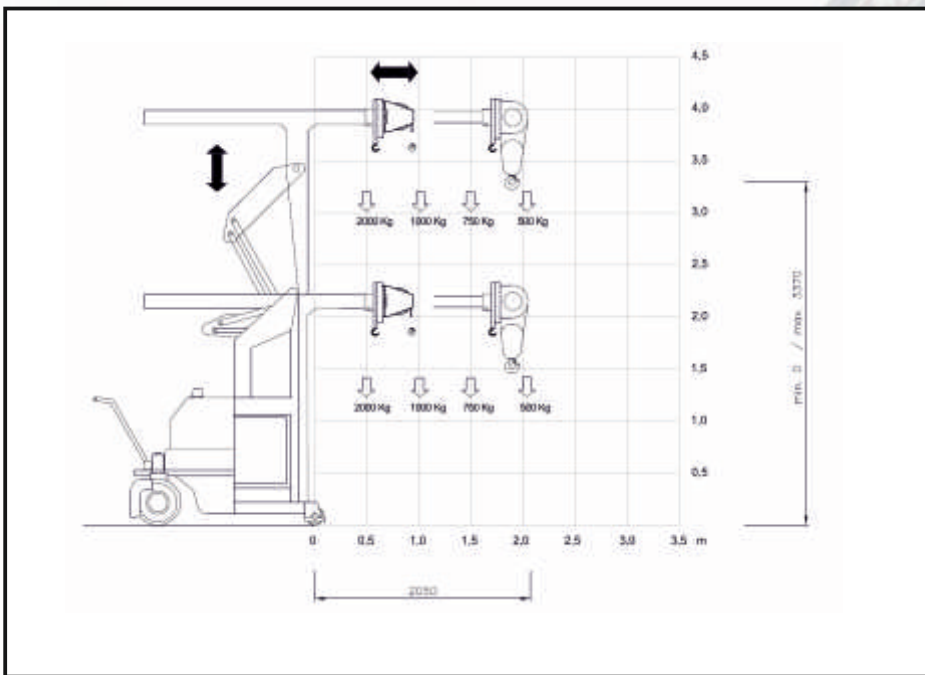

-  ŻURAW ELEKTROHYDRAULICZNY 2T
- charakterystyka udźwigu
-  ELECTRO-HYDRAULIC CRANE 2T
- lifting capacity specifications
-  GRU ELETTRIDRAULICA 2T
- caratteristiche di portata



-  ŻURAW ELEKTROHYDRAULICZNY 2T - wymiary
-  ELECTRO-HYDRAULIC CRANE 2T - dimensions
-  GRU ELETTRIDRAULICA 2T - dimensioni

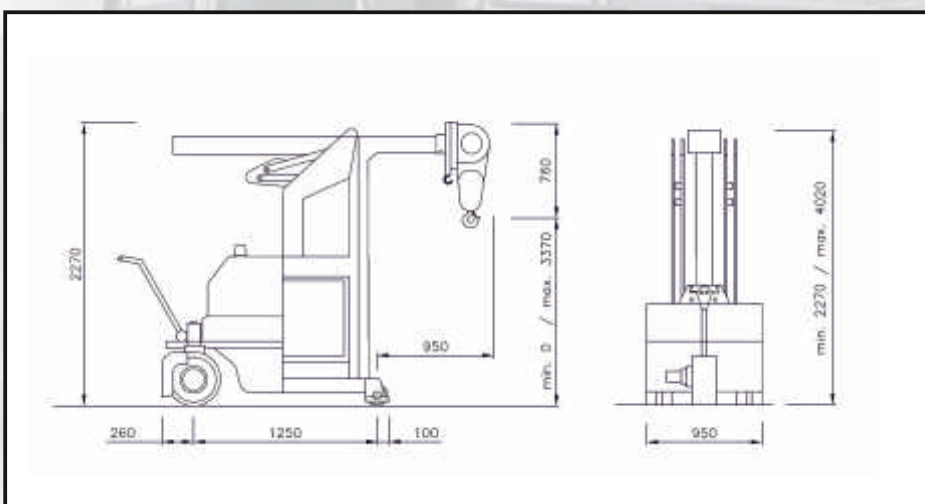

Alfa Poland

AUTOMATION SYSTEMS

Alfa Poland Sp. z o.o.
ul. Grażyńskiego 141
43-300 Bielsko-Biała
tel.: +48 33 488 55 00
alfapoland@alfapoland.pl
www.alfapoland.pl



Alfa Poland

AUTOMATION SYSTEMS

Alfa Poland Sp. z o.o.
ul. Grażyńskiego 141
43-300 Bielsko-Biała
tel.: +48 33 488 55 00
alfapoland@alfapoland.pl
www.alfapoland.pl



WÓZKI WIDŁOWE



FORKLIFTS



CARRELLI ELEVATORI

Alfa Poland

AUTOMATION SYSTEMS

Alfa Poland Sp. z o.o.
ul. Grażyńskiego 141
43-300 Bielsko-Biała
tel.: +48 33 488 55 00
alfapoland@alfapoland.pl
www.alfapoland.pl

 WÓZEK WIDŁOWY DIESEL 3T OM

 FORKLIFT DIESEL 3T OM



 CARRELLO ELEVATORE 3T OM







Alfa Poland

AUTOMATION SYSTEMS

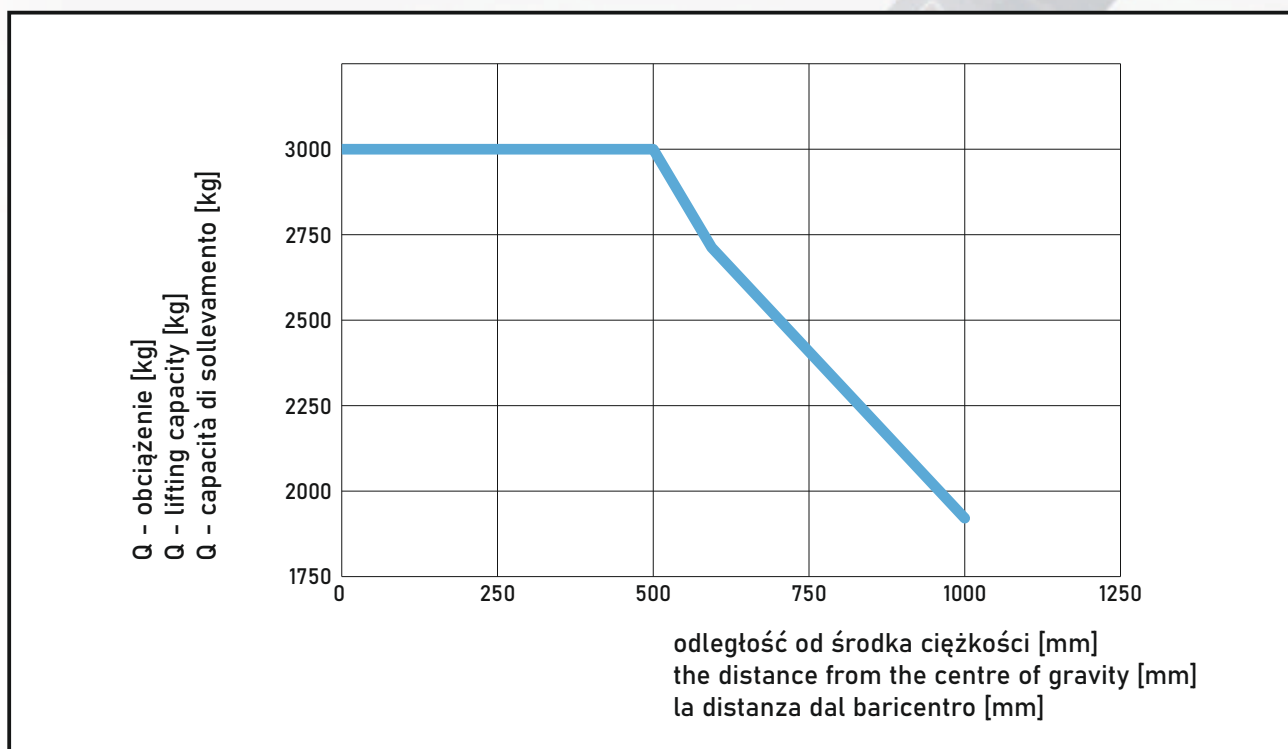
Alfa Poland Sp. z o.o.
ul. Grażyńskiego 141
43-300 Bielsko-Biała
tel.: +48 33 488 55 00
alfapoland@alfapoland.pl
www.alfapoland.pl

-  WÓZEK WIDŁOWY DIESEL 3T OM - charakterystyka udźwigu
-  FORKLIFT DIESEL 3T OM - lifting capacity specifications
-  CARRELLO ELEVATORE 3T OM - caratteristiche di portata



-  WÓZEK WIDŁOWY DIESEL 3T DI30CH OM - wymiary
-  FORKLIFT DIESEL 3T DI30CH OM - dimensions
-  CARRELLO ELEVATORE DI30CH 3T OM - dimensioni

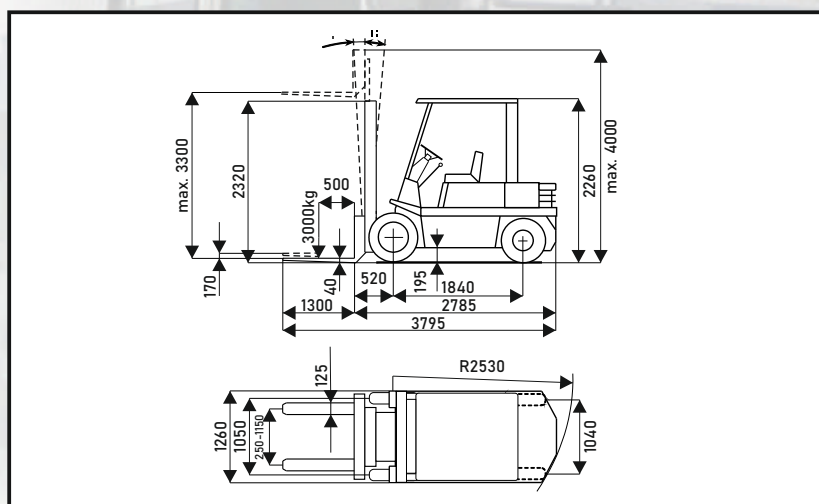

Alfa Poland

AUTOMATION SYSTEMS

Alfa Poland Sp. z o.o.
ul. Grażyńskiego 141
43-300 Bielsko-Biała
tel.: +48 33 488 55 00
alfapoland@alfapoland.pl
www.alfapoland.pl



WÓZEK WIDŁOWY ELEKTRYCZNY 4T STILL R60-40



FORKLIFT 4T STILL R60-40 ELECTRIC



CARRELLO ELEVATORE 4T STILL R60-40 ELETTRICO





STILL







Alfa Poland

AUTOMATION SYSTEMS

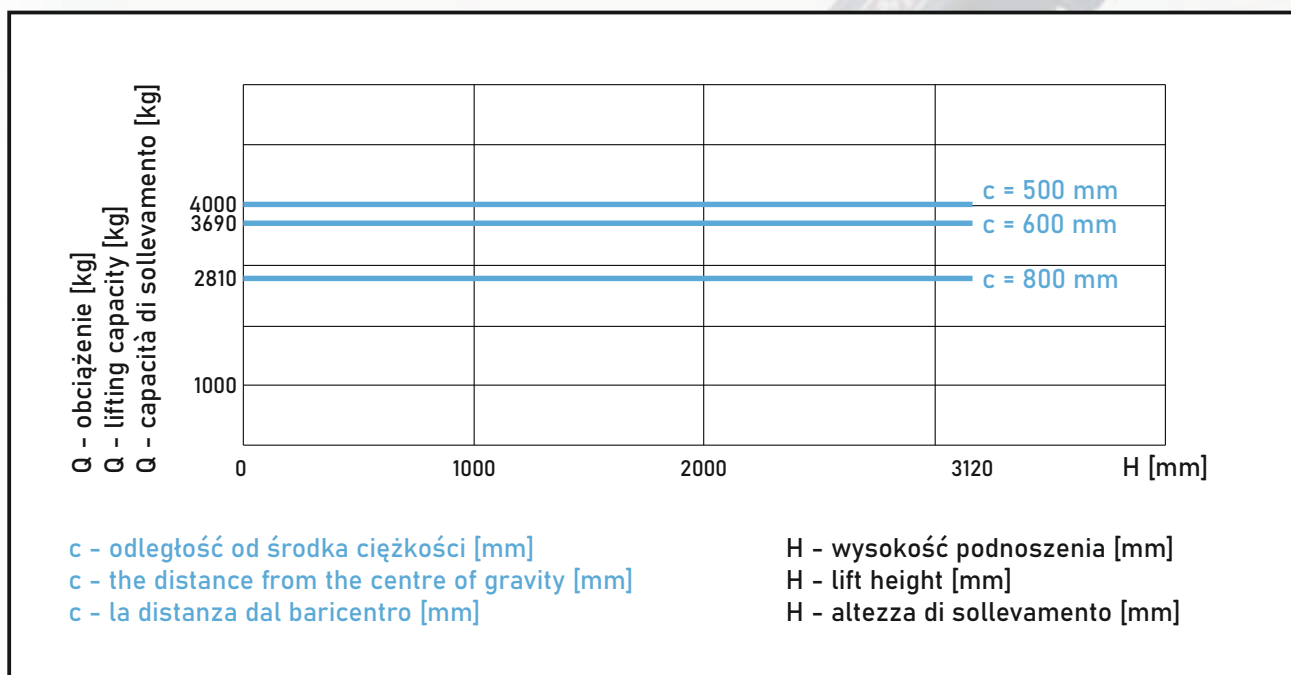
Alfa Poland Sp. z o.o.
ul. Grażyńskiego 141
43-300 Bielsko-Biała
tel.: +48 33 488 55 00
alfapoland@alfapoland.pl
www.alfapoland.pl

-  **WÓZEK WIDŁOWY ELEKTRYCZNY 4T STILL R60-40**
- charakterystyka udźwigu
-  **FORKLIFT 4T STILL R60-40 ELECTRIC**
- lifting capacity specifications
-  **CARRELLO ELEVATORE 4T STILL R60-40 ELETTRICO**
- caratteristiche di portata

-  **WÓZEK WIDŁOWY ELEKTRYCZNY 4T STILL R60-40 - wymiary**
-  **FORKLIFT 4T STILL R60-40 ELECTRIC - dimensions**
-  **CARRELLO ELEVATORE 4T STILL R60-40 ELETTRICO - dimensioni**

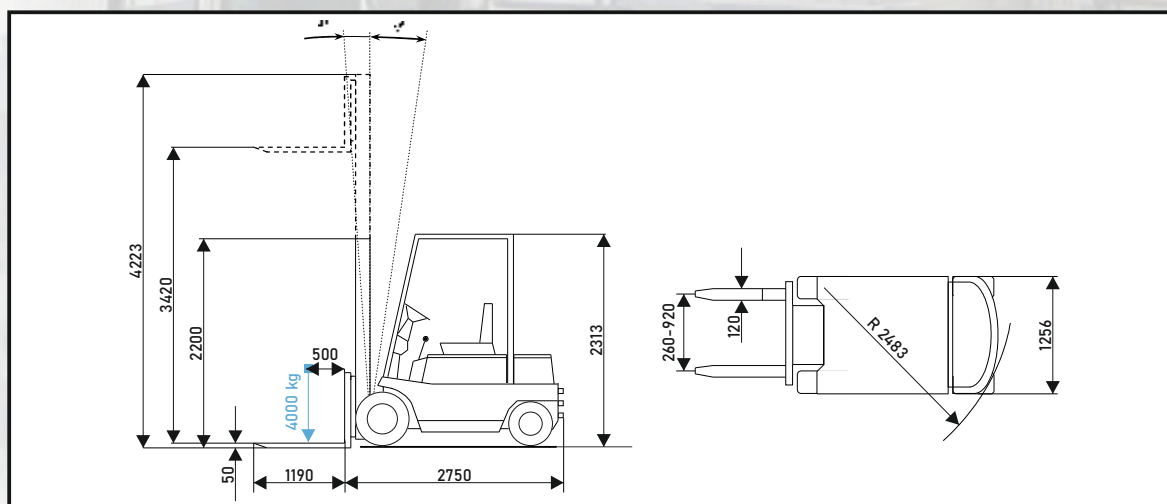

Alfa Poland

AUTOMATION SYSTEMS

Alfa Poland Sp. z o.o.
ul. Grażyńskiego 141
43-300 Bielsko-Biała
tel.: +48 33 488 55 00
alfapoland@alfapoland.pl
www.alfapoland.pl



WÓZEK WIDŁOWY ELEKTRYCZNY 5T LUGLI EHX50



FORKLIFT 5T LUGLI EHX50 ELECTRIC



CARRELLO ELEVATORE 5T LUGLI EHX50 ELETTRICO

LUGLI



Alfa Poland

AUTOMATION SYSTEMS

Alfa Poland Sp. z o.o.
ul. Grażyńskiego 141
43-300 Bielsko-Biała
tel.: +48 33 488 55 00
alfapoland@alfapoland.pl
www.alfapoland.pl

 **WÓZEK WIDŁOWY ELEKTRYCZNY 5T LUGLI EHX50**
- charakterystyka udźwigu

LUGLI

 **FORKLIFT 5T LUGLI EHX50 ELECTRIC**
- lifting capacity specifications

 **CARRELLO ELEVATORE 5T LUGLI EHX50 ELETTRICO**
- caratteristiche di portata

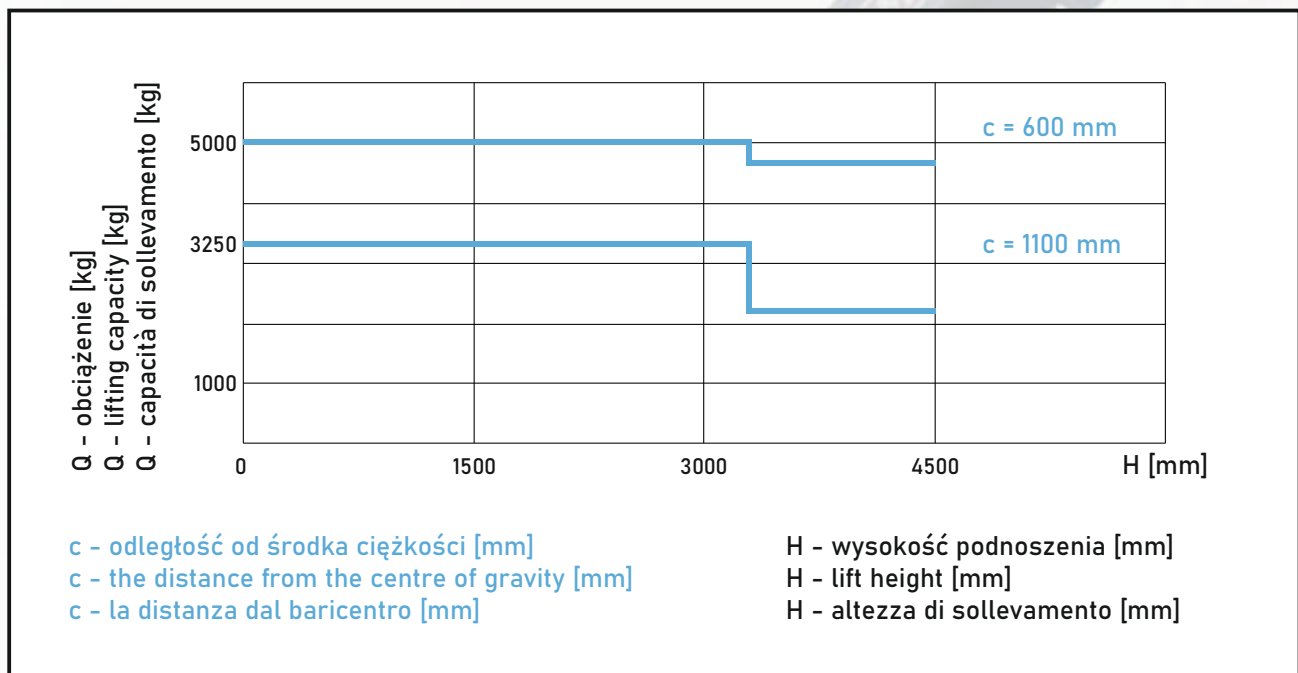

 **WÓZEK WIDŁOWY ELEKTRYCZNY 5T LUGLI EHX50 - wymiary**

 **FORKLIFT 5T LUGLI EHX50 ELECTRIC - dimensions**

 **CARRELLO ELEVATORE 5T LUGLI EHX50 ELETTRICO - dimensioni**

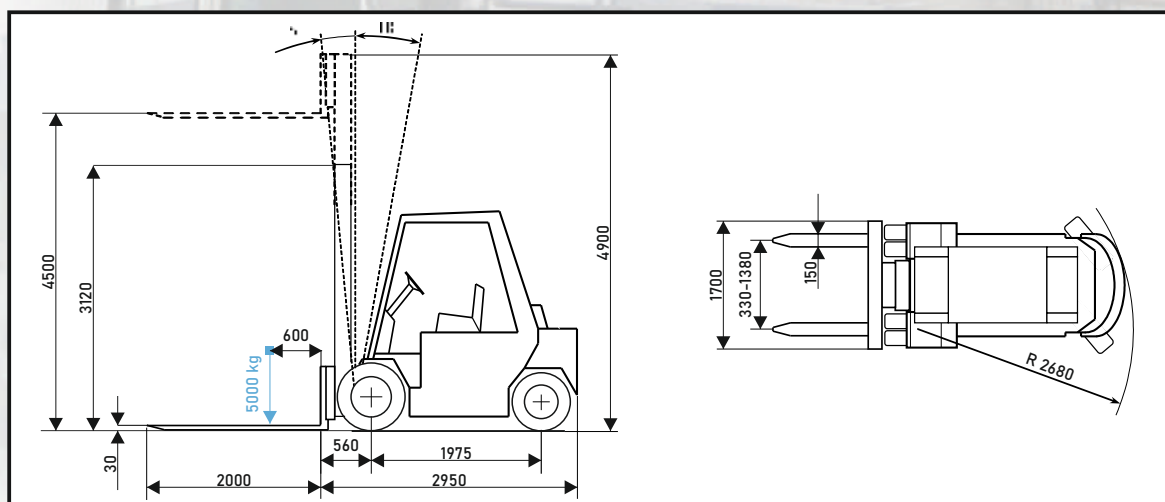

Alfa Poland

AUTOMATION SYSTEMS

Alfa Poland Sp. z o.o.
ul. Grażyńskiego 141
43-300 Bielsko-Biała
tel.: +48 33 488 55 00
alfapoland@alfapoland.pl
www.alfapoland.pl



WÓZEK WIDŁOWY ELEKTRYCZNY 3T CATERPILLAR



FORKLIFT 3T CATERPILLAR F60DSA ELECTRIC



CARRELLO ELEVATORE 3T CATERPILLAR ELETTRICO



CATERPILLAR[®]







Alfa Poland

AUTOMATION SYSTEMS

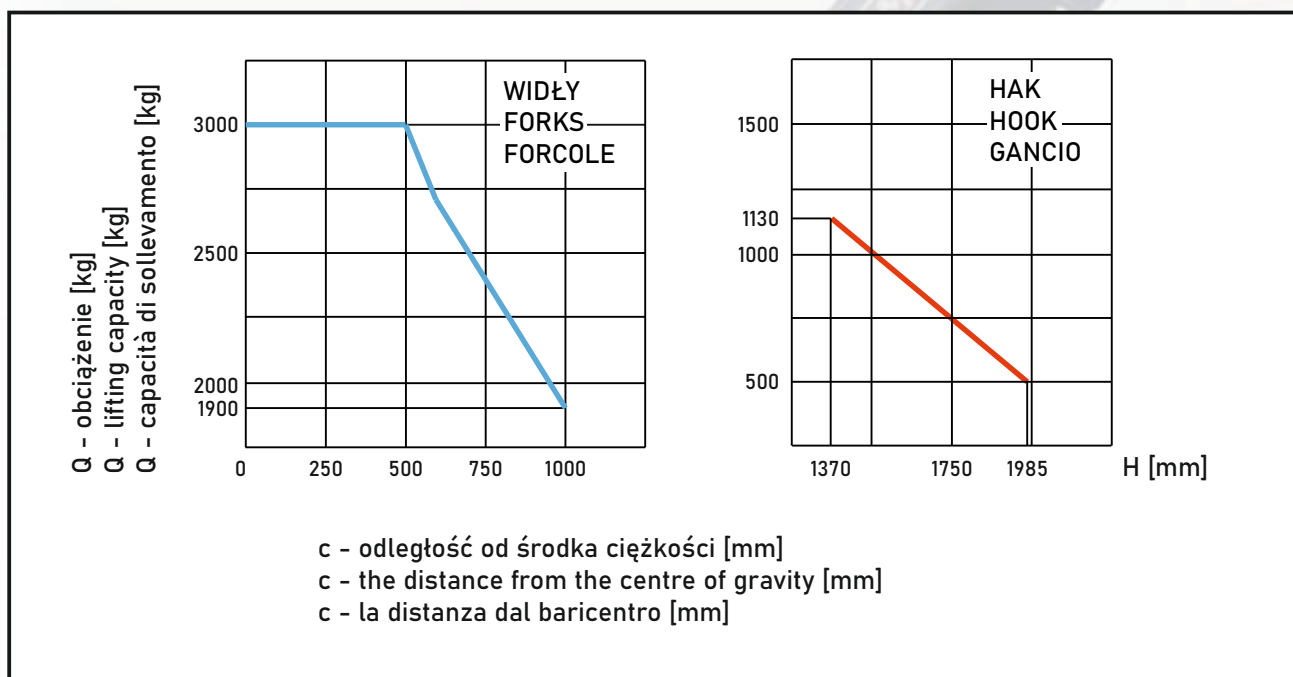
Alfa Poland Sp. z o.o.
ul. Grażyńskiego 141
43-300 Bielsko-Biała
tel.: +48 33 488 55 00
alfapoland@alfapoland.pl
www.alfapoland.pl

-  **WÓZEK WIDŁOWY ELEKTRYCZNY 3T CATERPILLAR**
- charakterystyka udźwigu **CATERPILLAR®**
-  **FORKLIFT 3T CATERPILLAR F60DSA ELECTRIC**
- lifting capacity specifications
-  **CARRELLO ELEVATORE 3T CATERPILLAR F60DSA ELETTRICO**
- caratteristiche di portata



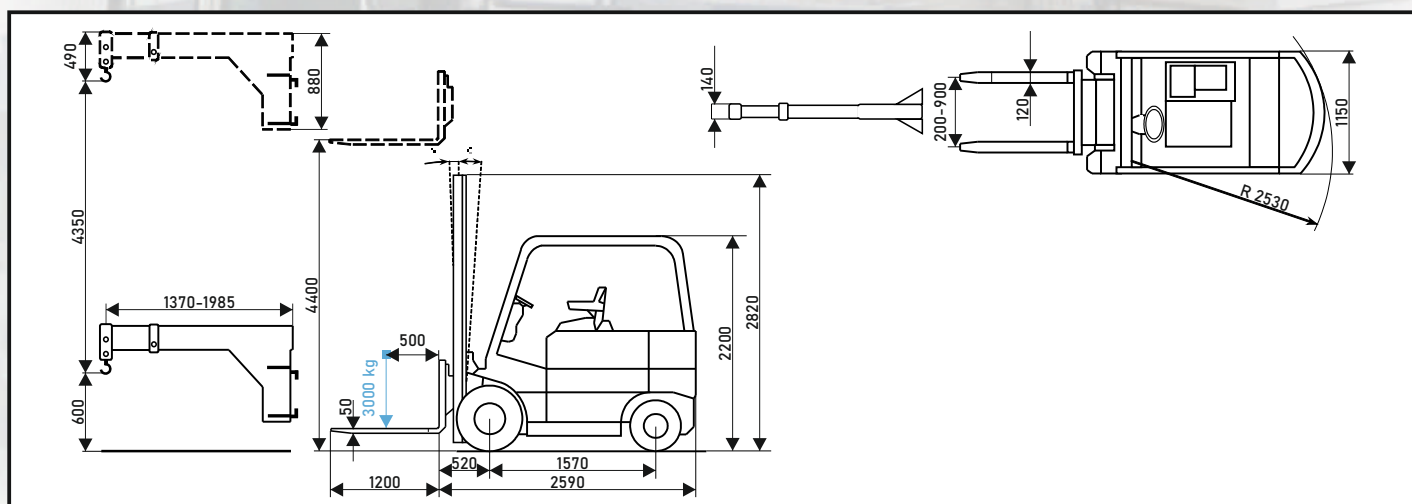

-  **WÓZEK WIDŁOWY ELEKTRYCZNY 3T CATERPILLAR - wymiary**
-  **FORKLIFT 3T CATERPILLAR F60DSA ELECTRIC - dimensions**
-  **CARRELLO ELEVATORE 3T CATERPILLAR ELETTRICO - dimensioni**



Alfa Poland

AUTOMATION SYSTEMS

Alfa Poland Sp. z o.o.
ul. Grażyńskiego 141
43-300 Bielsko-Biała
tel.: +48 33 488 55 00
alfapoland@alfapoland.pl
www.alfapoland.pl

-  WÓZEK WIDŁOWY ELEKTRYCZNY 8T OM FIAT
-  FORKLIFT 8T OM FIAT ELECTRIC
-  CARRELLO ELEVATORE 8T OM FIAT ELETTRICO



Alfa Poland

AUTOMATION SYSTEMS

Alfa Poland Sp. z o.o.
ul. Grażyńskiego 141
43-300 Bielsko-Biała
tel.: +48 33 488 55 00
alfapoland@alfapoland.pl
www.alfapoland.pl

 **WÓZEK WIDŁOWY ELEKTRYCZNY 8T OM FIAT**
- charakterystyka udźwigu

 **FORKLIFT 8T OM FIAT ELECTRIC**
- lifting capacity specifications

 **CARRELLO ELEVATORE 8T OM FIAT ELETTRICO**
- caratteristiche di portata

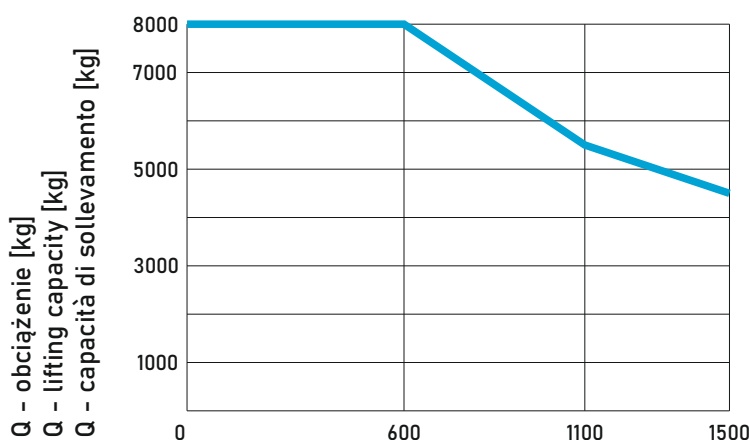

Parametry pracy:
Operating parameters:
Parametri di funzionamento:

- Przechył 7°
- Wysokość podnoszenia: 4500 mm
- Promień skrętu: 3050 mm

- 7° tilt
- Lifting height: 4500 mm
- Turning radius: 3050 mm

- Inclinazione di 7
- Altezza di sollevamento: 4500 mm
- Raggio di sterzata: 3050 mm

c - położenie ładunku na widłach [mm]
c - position of the load on the forks [mm]
c - posizione del carico sulle forche [mm]

 **WÓZEK WIDŁOWY ELEKTRYCZNY 8T OM FIAT - dane techniczne**

 **FORKLIFT 8T OM FIAT ELECTRIC - technical data**

 **CARRELLO ELEVATORE 8T OM FIAT ELETTRICO - dati tecnici**

- długość do czopa widet: 3380 mm
- szerokość 2100 mm
- wysokość masztu: 3300-5550 mm (opuszczony-podniesiony)
- widły: 60x200 mm
- wysokość kabiny: 2630 mm
- masa własna: 11450 kg

- length to fork face: 3380 mm
- width 2100 mm
- mast height: 3300-5550 mm (lowered-lifted)
- forks: 60x200 mm
- cab height: 2630 mm
- empty weight: 11450 kg

- lunghezza fino alla forcella: 3380 mm
- larghezza 2100 mm
- altezza del montante: 3300-5550 mm (abbassato-alzato)
- forcelle: 60x200 mm
- altezza della cabina: 2630 mm
- peso a vuoto: 11450 kg

Alfa Poland

AUTOMATION SYSTEMS

Alfa Poland Sp. z o.o.
ul. Grażyńskiego 141
43-300 Bielsko-Biała
tel.: +48 33 488 55 00
alfapoland@alfapoland.pl
www.alfapoland.pl



Alfa Poland

AUTOMATION SYSTEMS

Alfa Poland Sp. z o.o.
ul. Grażyńskiego 141
43-300 Bielsko-Biała
tel.: +48 33 488 55 00
alfapoland@alfapoland.pl
www.alfapoland.pl



PODESTY SAMOJEZDNE



MOBILE WORKING PLATFORMS



PIATTAFORME MOBILI

Alfa Poland

AUTOMATION SYSTEMS

Alfa Poland Sp. z o.o.
ul. Grażyńskiego 141
43-300 Bielsko-Biała
tel.: +48 33 488 55 00
alfapoland@alfapoland.pl
www.alfapoland.pl



PODEST SAMOJEZDNY ELEKTRYCZNY AIRO SG1400J-E



SELF-PROPELLED PLATFORM AIRO SG1400J-E ELECTRIC



PIATTAFORMA AEREA AIRO SG1400J-E ELETTRICA

AIRO





Alfa Poland

AUTOMATION SYSTEMS

Alfa Poland Sp. z o.o.
ul. Grażyńskiego 141
43-300 Bielsko-Biała
tel.: +48 33 488 55 00
alfapoland@alfapoland.pl
www.alfapoland.pl

 **PODEST SAMOJEZDNY ELEKTRYCZNY AIRO SG1400J-E**
- charakterystyka wysięgnika

 **SELF-PROPELLED PLATFORM AIRO SG1400J-E ELECTRIC**
- boom specification

 **PIATTAFORMA AEREA AIRO SG1400J-E ELETTRICA**
- caratteristiche del braccio

AIRO

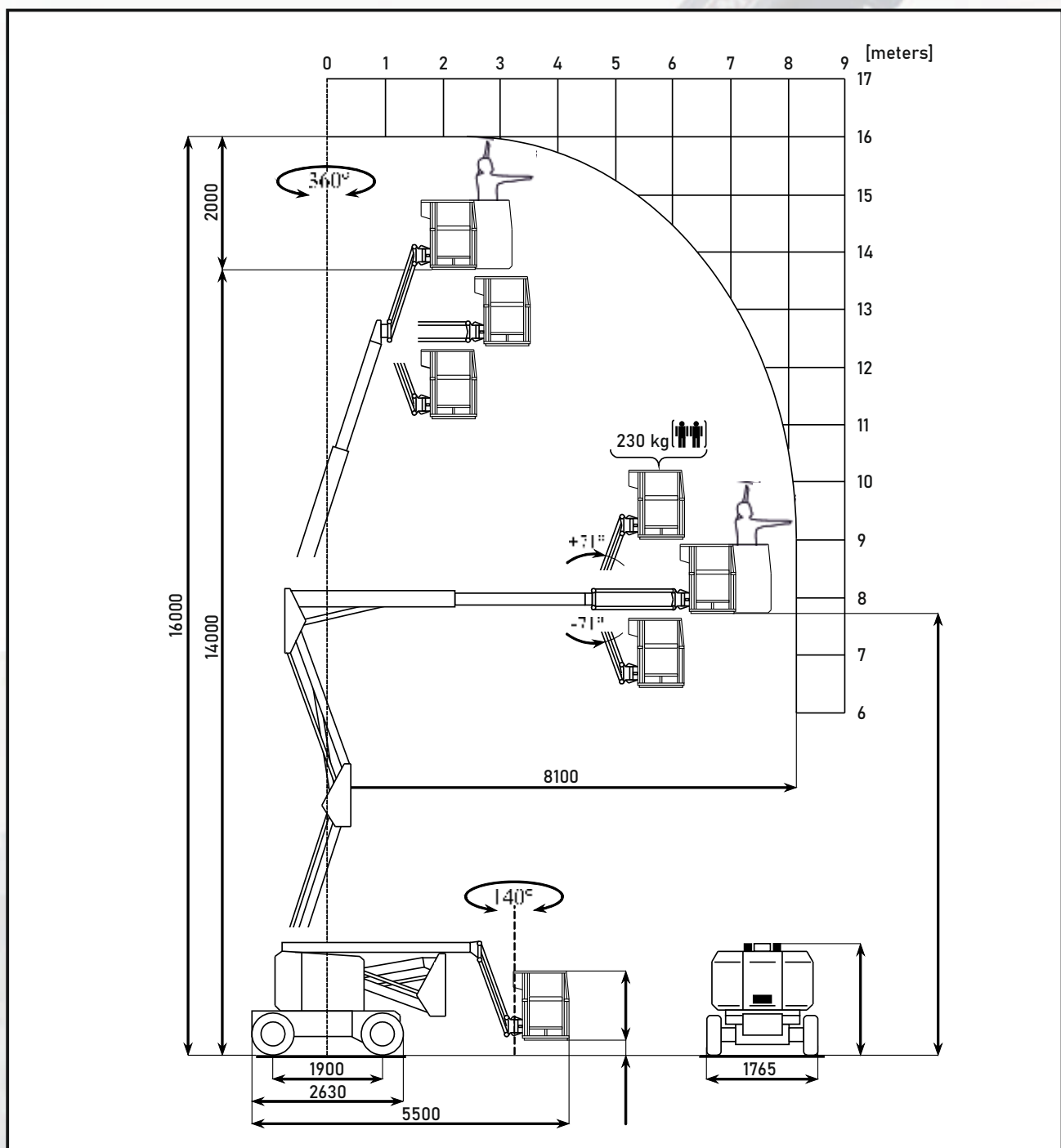

Alfa α Poland

AUTOMATION SYSTEMS

Alfa Poland Sp. z o.o.
ul. Grażyńskiego 141
43-300 Bielsko-Biała
tel.: +48 33 488 55 00
alfapoland@alfapoland.pl
www.alfapoland.pl



PODEST SAMOJEZDNY ELEKTRYCZNY AIRO SG1100J



SELF-PROPELLED PLATFORM AIRO SG1100J ELECTRIC



PIATTAFORMA AEREA AIRO SG1100J ELETTRICA



AIRO



Alfa Poland

AUTOMATION SYSTEMS

Alfa Poland Sp. z o.o.
 ul. Grażyńskiego 141
 43-300 Bielsko-Biała
 tel.: +48 33 488 55 00
 alfapoland@alfapoland.pl
 www.alfapoland.pl

-  **PODEST SAMOJEZDNY ELEKTRYCZNY AIRO SG1100J**
 - charakterystyka wysięgnika
-  **SELF-PROPELLED PLATFORM AIRO SG1100J ELECTRIC**
 - boom specification
-  **PIATTAFORMA AEREA AIRO SG1100J ELETTRICA**
 - caratteristiche del braccio

AIRO

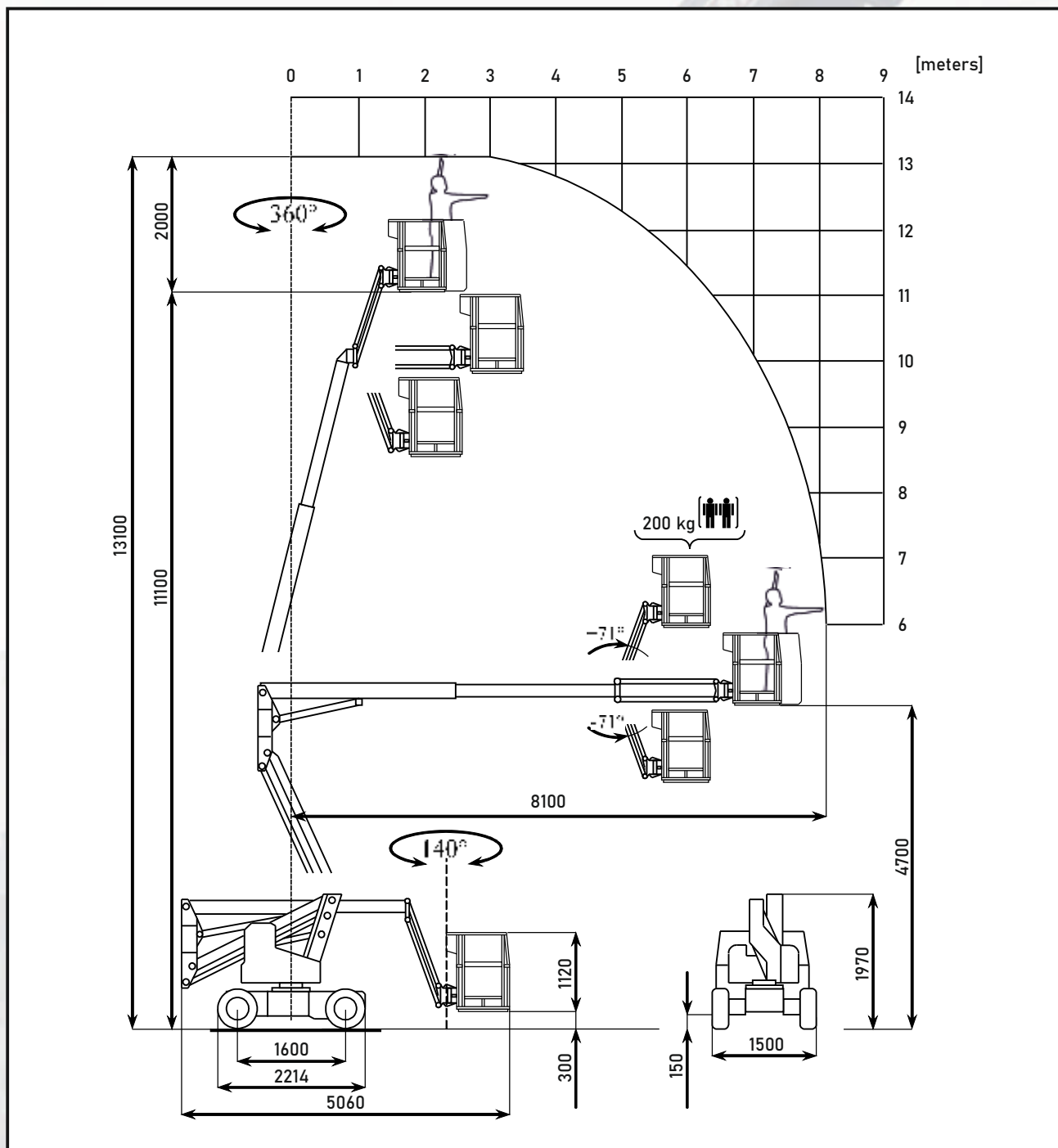

Alfa Poland

AUTOMATION SYSTEMS

Alfa Poland Sp. z o.o.
ul. Grażyńskiego 141
43-300 Bielsko-Biała
tel.: +48 33 488 55 00
alfapoland@alfapoland.pl
www.alfapoland.pl



PODEST SAMOJEZDNY ELEKTRYCZNY AIRO SF820



SELF-PROPELLED PLATFORM AIRO SF820 ELECTRIC



PIATTAFORMA AEREA AIRO SF820 ELETTRICA



AIRO



Alfa Poland

AUTOMATION SYSTEMS

Alfa Poland Sp. z o.o.
ul. Grażyńskiego 141
43-300 Bielsko-Biała
tel.: +48 33 488 55 00
alfapoland@alfapoland.pl
www.alfapoland.pl

-  **PODEST SAMOJEZDNY ELEKTRYCZNY AIRO SF820**
- charakterystyka wysięgnika
-  **SELF-PROPELLED PLATFORM AIRO SF820 ELECTRIC**
- boom specification
-  **PIATTAFORMA AEREA AIRO SF820 ELETTRICA**
- caratteristiche del braccio

AIRO

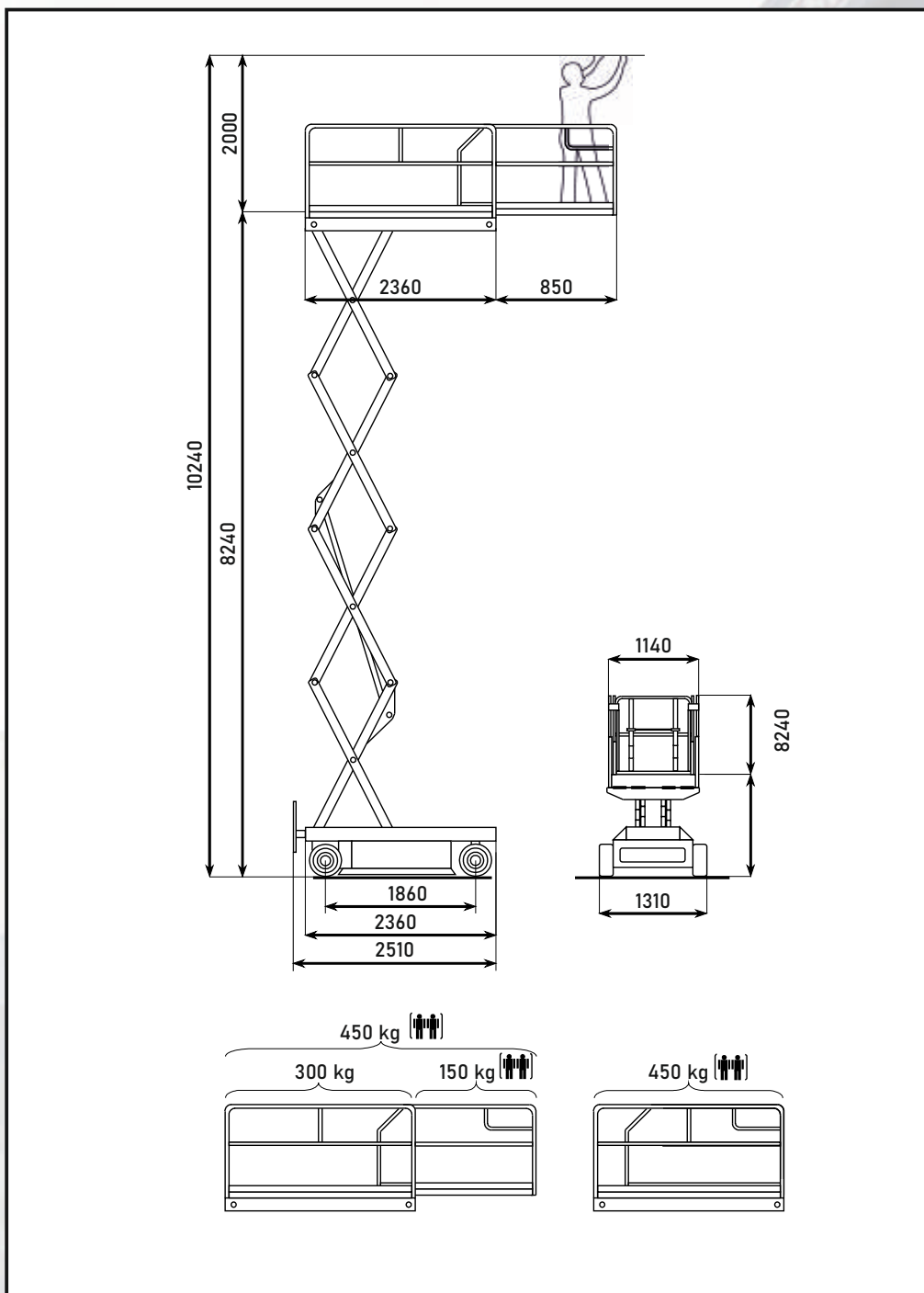

Alfa Poland

AUTOMATION SYSTEMS

Alfa Poland Sp. z o.o.
ul. Grażyńskiego 141
43-300 Bielsko-Biała
tel.: +48 33 488 55 00
alfapoland@alfapoland.pl
www.alfapoland.pl



Alfa Poland

AUTOMATION SYSTEMS

Alfa Poland Sp. z o.o.
ul. Grażyńskiego 141
43-300 Bielsko-Biała
tel.: +48 33 488 55 00
alfapoland@alfapoland.pl
www.alfapoland.pl



**TRANSPORT NISKOPODWOZIOWY
SPRZĘTU CIĘŻKIEGO**



HAVY MACHINERY LOW LOADER TRANSPORT





**CAMION A BASSO CARICO
PER IL TRASPORTO DI MEZZI PESANTI**



Alfa Poland

AUTOMATION SYSTEMS



Alfa Poland Sp. z o.o.
ul. Grażyńskiego 141
43-300 Bielsko-Biała
tel.: +48 33 488 55 00
alfapoland@alfapoland.pl
www.alfapoland.pl

-  CIĄGNIK SPECJALNY MAN
-  MAN SPECIAL TRACTOR
-  TRATTORE STRADALE SPECIALE MAN

Masa własna: Weight: Peso a vuoto:	Masa całkowita maksymalna: Maximum total weight: Peso totale massimo:
8100 kg	26000 kg

-  CIĘŻAROWA NISKOPODWOZIOWA NACZEPA NAJAZDOWA
-  TRUCK ROLLOVER LOW LOADER TRAILER
-  SEMIRIMORCHIO A PIANALE RIBASSATO

Masa własna: Weight: Peso a vuoto:	Masa całkowita maksymalna: Maximum total weight: Peso totale massimo:	Dopuszczalne obciążenie: Maximum load: Carico massimo ammissibile:
8460 kg	32000 kg	23540 kg

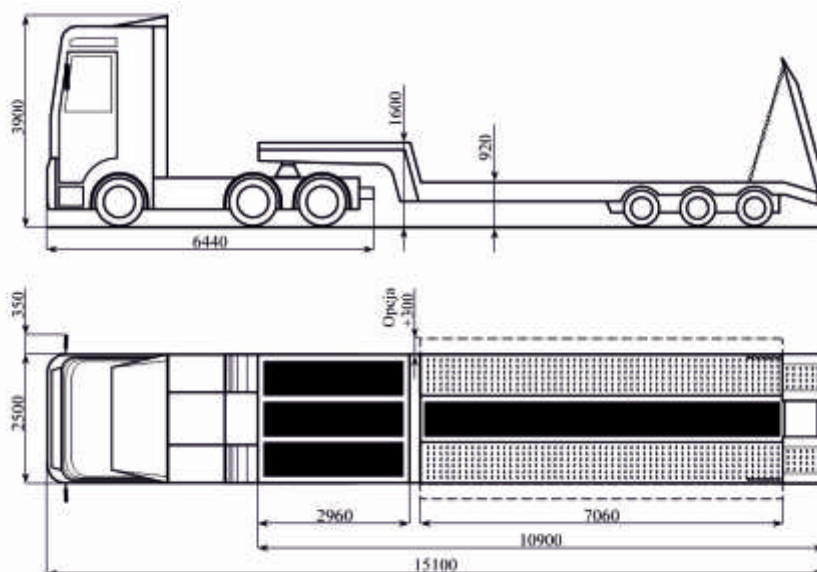

-  WYMIARY
-  DIMENSIONS
-  DIMENSIONI



Alfa Poland

AUTOMATION SYSTEMS

Alfa Poland Sp. z o.o.
ul. Grażyńskiego 141
43-300 Bielsko-Biała
tel.: +48 33 488 55 00
alfapoland@alfapoland.pl
www.alfapoland.pl

-  CIĄGNIK SIODŁOWY MAN Z NACZEPĄ NISKOPODŁOGOWĄ
-  MAN TRUCK TRACTOR WITH LOW FLOOR TRAILER
-  TRATTORE MAN CON SEMIRIMORCHIO A PIANALE RIBASSATO



Alfa α Poland

AUTOMATION SYSTEMS

Alfa Poland Sp. z o.o.
ul. Grażyńskiego 141
43-300 Bielsko-Biała
tel.: +48 33 488 55 00
alfapoland@alfapoland.pl
www.alfapoland.pl



Alfa Poland

AUTOMATION SYSTEMS

Alfa Poland Sp. z o.o.
ul. Grażyńskiego 141
43-300 Bielsko-Biała
tel.: +48 33 488 55 00
alfapoland@alfapoland.pl
www.alfapoland.pl



OSPRZĘT DODATKOWY



ADDITIONAL EQUIPMENT





ACCESSORI

Alfa Poland



AUTOMATION SYSTEMS

Alfa Poland Sp. z o.o.
ul. Grażyńskiego 141
43-300 Bielsko-Biała
tel.: +48 33 488 55 00
alfapoland@alfapoland.pl
www.alfapoland.pl

-  PODNOŚNIKI O UDŹWIGU DO 15T
-  JACKS WITH LIFTING CAPACITY OF 15T
-  SOLLEVATORI DALLA PORTATA DI 15T



Każdy podnośnik może podnieść masę do 15T na wysokość do 30 cm
Each jack can lift the weight up to 15T to a height up to 30 cm
Ogni sollevatore può sollevare il peso fino a 15T ad un'altezza di 30 cm

-  ROLKI O NOŚNOŚCI DO 24T ORAZ DO 50T
-  ROLLERS WITH CARRYING CAPACITY UP TO 24T AND 50T
-  RULLI CON LA PORTATA FINO A 24T E A 50T



Alfa Poland

AUTOMATION SYSTEMS

Alfa Poland Sp. z o.o.
ul. Grażyńskiego 141
43-300 Bielsko-Biała
tel.: +48 33 488 55 00
alfapoland@alfapoland.pl
www.alfapoland.pl

 TRAWERSY O UDŹWIGU DO 15T ORAZ DO 22T

 TRAVERSES WITH LIFTING CAPACITY UP TO 15T AND 22T

 TRAVERSA DALLA PORTATA FINO A 15T E A 22T

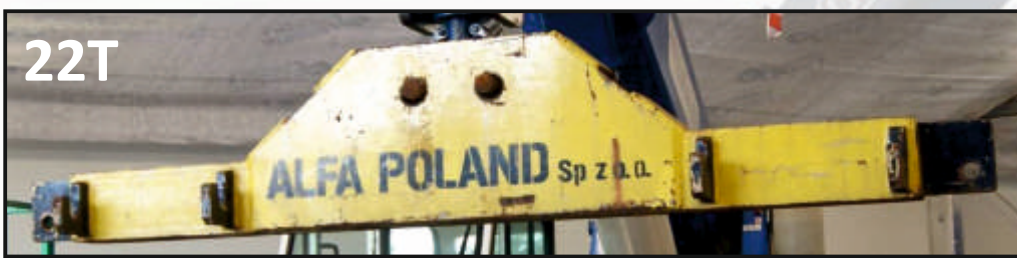

Udźwig: Lifting capacity / Portata:	Długość: Length / Lunghezza:	Wysokość: Height / Altezza:	Szerokość: Width / Larghezza:
15 T	3560 mm	510 mm	240 mm
22 T	2530 mm	480 mm	400 mm

 PLATFORMY O NOŚNOŚCI DO 15T ORAZ DO 25T

 PLATFORMS WITH CARRYING CAPACITY UP TO 15T AND 25T

 PIATTAFORME CON LA PORTATA DI A 15T E A 25T



Udźwig: Lifting capacity / Portata:	Długość: Length / Lunghezza:	Wysokość: Height / Altezza:	Szerokość: Width / Larghezza:
15 T	4000 mm	550 mm	2200 mm
25 T	4020 mm	580 mm	2600 mm

Alfa Poland

AUTOMATION SYSTEMS

Alfa Poland Sp. z o.o.
ul. Grażyńskiego 141
43-300 Bielsko-Biała
tel.: +48 33 488 55 00
alfapoland@alfapoland.pl
www.alfapoland.pl



ŁAŃCUCHY OD 3M DO 4M O UDŹWIGU DO 44T



STEEL CHAINS 3M TO 4M WITH LIFTING CAPACITY UP TO 44T



CATENE 3-4M CON LA PORTATA FINO A 44T



PASY KOLISTE OD 3M DO 5M O UDŹWIGU DO 8T W LINII PROSTEJ



CIRCULAR BELTS 3-5M, LIFTING CAP. UP TO 8T IN A STRAIGHT LINE



CINGHIE CIRCOLARI 3-5M CON LA PORTATA FINO A 8T IN LINEA RETTA

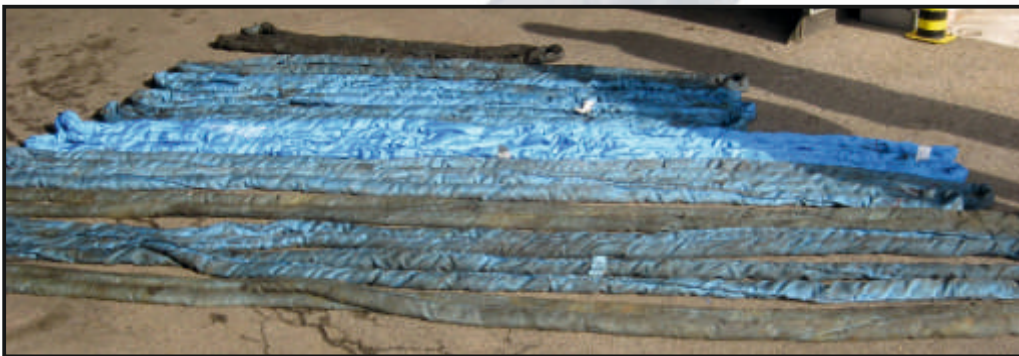

PASY PŁASKIE OD 2M DO 5M O UDŹWIGU DO 4T W LINII PROSTEJ



FLAT BELTS 2-5M, LIFTING CAP. UP TO 4T IN A STRAIGHT LINE



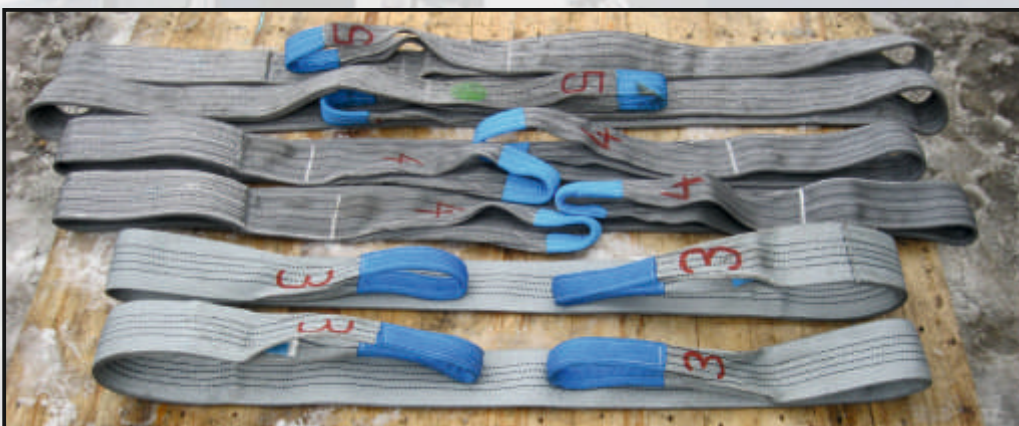

CINGHIE PIATTE 2-5M CON LA PORTATA FINO A 4T IN LINEA RETTA



Alfa Poland



AUTOMATION SYSTEMS

Alfa Poland Sp. z o.o.
ul. Grażyńskiego 141
43-300 Bielsko-Biała
tel.: +48 33 488 55 00
alfapoland@alfapoland.pl
www.alfapoland.pl

-  WAŁKI STALOWE
-  STEEL ROLLS
-  ALBERI DI ACCIAIO



Średnica liny: Diameter: Diametro:	Długość: Length: Lunghezza:	Ilość: Quantities: Quantita':
60 mm	1600 mm	4
60 mm	1000 mm	2
80 mm	2400 mm	2
80 mm	1500 mm	2
90 mm	3000 mm	2
90 mm	2700 mm	2
90 mm	2500 mm	2
100 mm	4000 mm	2
100 mm	2860 mm	2
100 mm	2000 mm	2

-  LINY STALOWE OD 2M DO 6M O UDŹWIGU OD 2 DO 8 TON
-  STEEL ROPES WITH LENGTH OF 2-6M, LIFTING CAPACITY OF 2-8T
-  FUNI DI ACCIAIO 2-6M CON LA PORTATA DI 2-8T

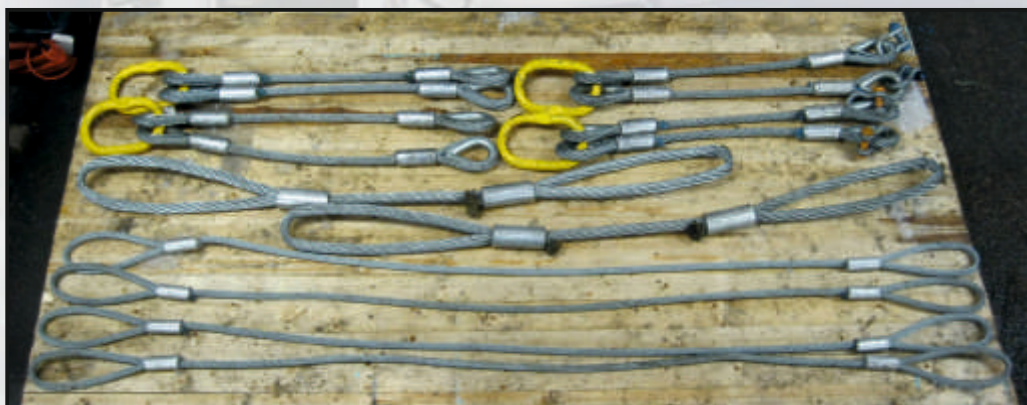

Alfa Poland

AUTOMATION SYSTEMS

Alfa Poland Sp. z o.o.
ul. Grażyńskiego 141
43-300 Bielsko-Biała
tel.: +48 33 488 55 00
alfapoland@alfapoland.pl
www.alfapoland.pl

 ZAPRASZAMY DO WSPÓŁPRACY

 WE INVITE YOU TO COOPERATE WITH US

 SPERIAMO DI POTER LAVORARE CON VOI

